



A Large Financial Institution Migrates Datacenters with No Downtime Using HPE Shadowbase ZDM

A Gravic, Inc. Case Study



Executive Summary

A major financial institution offers money transfers that allow customers to deposit money, and then sends a notification to the designated recipient of the money transfer. The recipient can have the money deposited to a bank account or can go to a company office to collect the money. Today, person-to-person money transfers, money orders, and business payments represent a significant amount of the company's business.



To support its money transfer activities, the company implemented an active/active HPE NonStop system to provide continuous availability. The two NonStop systems comprising the active/active system were located in separate locations 1,000 miles apart, and their databases were kept synchronized with bi-directional data replication. A transaction could be sent to either system for processing, with changes made to one database immediately replicated to the other database. System users were distributed between the two servers of the active/active pair.

The company decided to physically move its datacenters to other cities, while upgrading one system's hardware, and replacing its existing data replication product during the sequence. It could not tolerate any application outage during the move. Its customers would still need to make money transfers as the services were in the process of being relocated and the other changes were taking place. In addition, the company required that full business continuity disaster tolerance be provided for the application while the project took place. Due to leasing restrictions, the entire process needed to be completed within a few weeks. In short, the company had a very challenging set of requirements.

The company turned to Gravic, Inc.'s HPE Shadowbase Zero Downtime Migration (ZDM) software to satisfy these requirements and relocate its servers with no application downtime while minimizing the risk inherent in this complex set of operations.¹

¹HPE Shadowbase ZDM is based on the Gravic Shadowbase data replication engine, which is sold by Hewlett Packard Enterprise (HPE) under the name *HPE Shadowbase*.

Table of Contents

Executive Summary	3
HPE Shadowbase Zero Downtime Migration (ZDM) Overview	4
The Company’s Migration Objectives	6
<i>Step 1: Install and Load the DC3 System in Datacenter 3</i>	7
<i>Step 2: Migrate Users from DC2 to DC3, Isolating DC2 for the Shutdown/Move</i>	8
<i>Step 3: Shutdown and Move the DC2 System to Datacenter 4 (Rename it to DC4)</i>	9
<i>Step 4: Migrate Users from DC1 to DC4 to Isolate the DC1 System</i>	10
<i>Step 5: Retire the DC1 System to Create the Final DC3/DC4 Active/Active Solution</i>	10
Summary	11
International Partner Information	12
HPE Shadowbase Contact Information	12

Table of Figures

Figure 1 – HPE Shadowbase ZDM Step 1	4
Figure 2 – HPE Shadowbase ZDM Step 2	4
Figure 3 – HPE Shadowbase ZDM Step 3	5
Figure 4 – HPE Shadowbase ZDM Step 4	5
Figure 5 – The Company’s Original Active/Active System	6
Figure 6 – The Company’s Final Active/Active System.....	7
Figure 7 – Add the DC3 Node	7
Figure 8 – Migrate Users from DC2 to DC3	8
Figure 9 – Migrate Users from DC2 to DC3	8
Figure 10 – Shutdown, Move, and Rename DC2 to DC4	9
Figure 11 – Move DC2 to DC4	9
Figure 12 – Migrate Users from DC1 to DC4	10
Figure 13 – Retire the DC1 System.....	10

HPE Shadowbase Zero Downtime Migration (ZDM) Overview

How is HPE Shadowbase ZDM able to migrate systems with no application downtime? An overview of the ZDM process is shown in Figure 1 through Figure 4. (Note that these figures do not reflect the subject company's actual system configuration, but demonstrate the general principles involved.)

Step 1: Set up the new system (Figure 1).

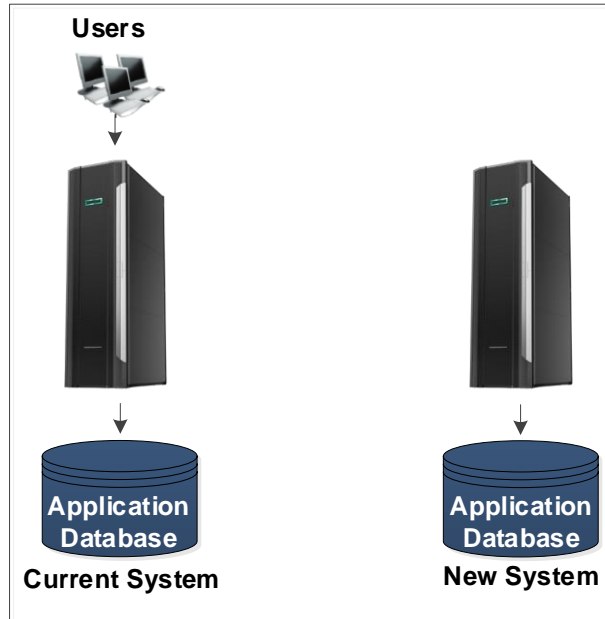

Figure 1 – HPE Shadowbase ZDM Step 1

Step 2: Load the existing source application database onto the new (target) system (Figure 2).

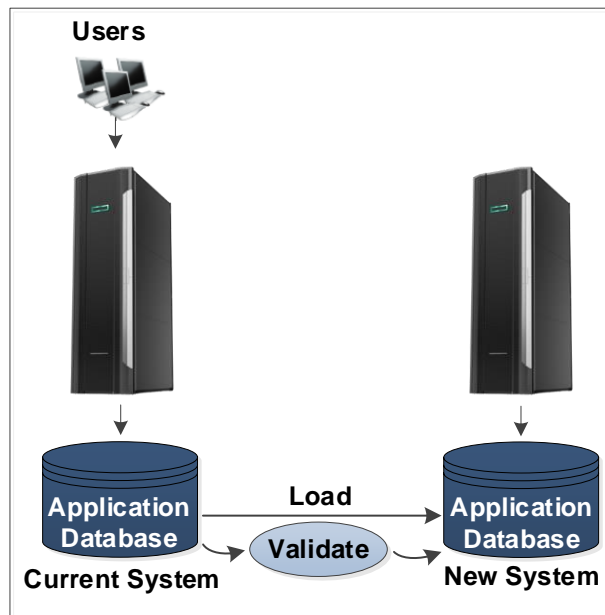

Figure 2 – HPE Shadowbase ZDM Step 2

Step 3: Test the new system (Figure 3). Once the load is complete, it is good practice to validate that the target database is an exact replica of the source database before proceeding. (The HPE Shadowbase Compare product may be used to perform this verification.) Uni-directional data replication is enabled so that the

database of the new system will remain synchronized with the current system while the current system continues to process transactions.

Step 3 allows the testers to work on a current copy of the production database to verify proper functioning with 'real' data.

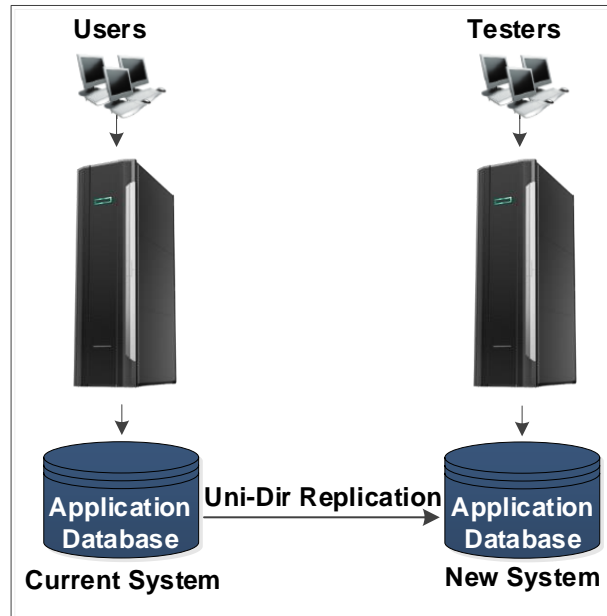

Figure 3 – HPE Shadowbase ZDM Step 3

Step 4: Enable bi-directional replication and move users to the new system (Figure 4). Finally, when the testing of the new system is complete, bi-directional replication is enabled in Step 4 and all users are moved to the new system (Figure 4).

Using bi-directional replication allows the original system's database to remain current when first using the new system, which greatly speeds a failback to the original system without losing any data.

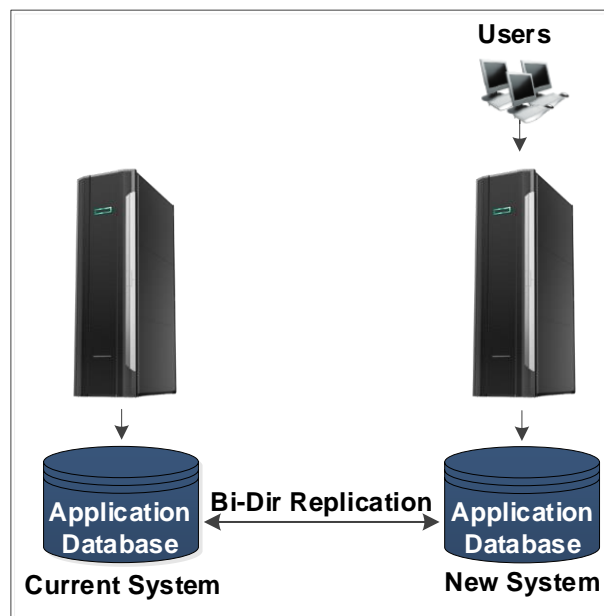

Figure 4 – HPE Shadowbase ZDM Step 4

After an appropriate period of time passes (to ensure the new system is properly functioning), the original system can be taken down (perhaps for its own upgrade).

Migration of users to the new system is therefore accomplished with no application downtime. Furthermore, the normal risks of migration are eliminated. Users are moved to a known properly functioning system, and the existing, unchanged system is always available, providing service. If there is a problem, users can quickly be returned to the original system until the problem is corrected. And, with bi-directional replication being deployed, any data modified on the new system is reverse-replicated to the original system so that no data will be lost if a failback occurs.²

In summary, even the most challenging of migrations (hardware, software, and location) can be undertaken efficiently and with low risk using HPE Shadowbase ZDM technology and methodology.

The Company's Migration Objectives

The company's original active/active system included a twelve-processor, four-core NonStop NB54000 system, DC1 (in Datacenter 1), and a similar system, DC2 (in Datacenter 2). The two systems were interconnected via the company's existing bi-directional data replication engine, called "Old Bi-Dir Replication," as shown in Figure 5.

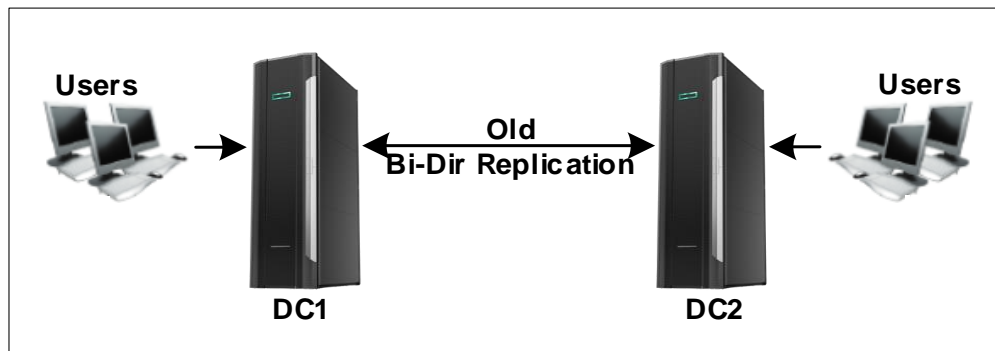

Figure 5 – The Company's Original Active/Active System

The company wanted to accomplish several objectives with its migration:

1. Retire DC1, a twelve-processor four-core NonStop NB54000 system, located in Datacenter 1, replacing it with a new twelve-processor four-core NonStop NB56000 system, called DC3, installed at a new datacenter location (Datacenter 3).
2. Move the DC2 system from Datacenter 2 to a new datacenter location (Datacenter 4), and rename the system DC4.
3. Replace its current data replication product ("Old Bi-Dir Replication") with a HPE Shadowbase active/active solution. (Its original data replication product was expensive, functionally stable and not being enhanced.)
4. Train its entire systems and operations center staff on HPE Shadowbase using a hands-on approach while the project occurred.
5. Achieve all of these goals with no application outage and no decrease in business continuity protection during the entire process. At all times, there must be at least two copies of the application and database available on two separate nodes.
6. Complete the project in a few short weeks as leases were expiring.

²For a more detailed description of HPE Shadowbase ZDM, please see the Gravic white paper, [Using HPE Shadowbase to Eliminate Planned Downtime via Zero Downtime Migration](#).

Figure 6 shows the company's final active/active system configuration:

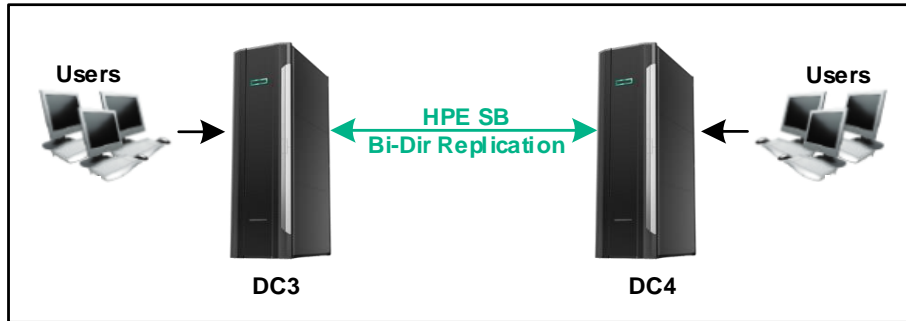

Figure 6 – The Company's Final Active/Active System

All of these objectives were met with the use of HPE Shadowbase ZDM. The migration migrated as follows:

- Step 1: Install and Load the DC3 System
- Step 2: Migrate Users from DC2 to DC3
- Step 3: Shutdown and Move the DC2 System to Datacenter 4 (Rename it to DC4)
- Step 4: Migrate Users from DC1 to DC4 to Isolate the DC1 System
- Step 5: Retire the DC1 System

The following sections drill down into the details of each step.

Step 1: Install and Load the DC3 System in Datacenter 3

The company's first step was to obtain its new NonStop NB56000 (DC3) and install it in Datacenter 3 (Figure 7). The company timestamped the Audit Trail in the DC1 system and loaded the DC3 database from the DC1 database with data up to the timestamp. The company next enabled HPE Shadowbase bi-directional replication between DC1 and DC3 and began replication to DC3 from the DC1 timestamp, keeping the DC3 database synchronized with the DC1 database. The DC3 system was then exhaustively tested and verified before being put into service.

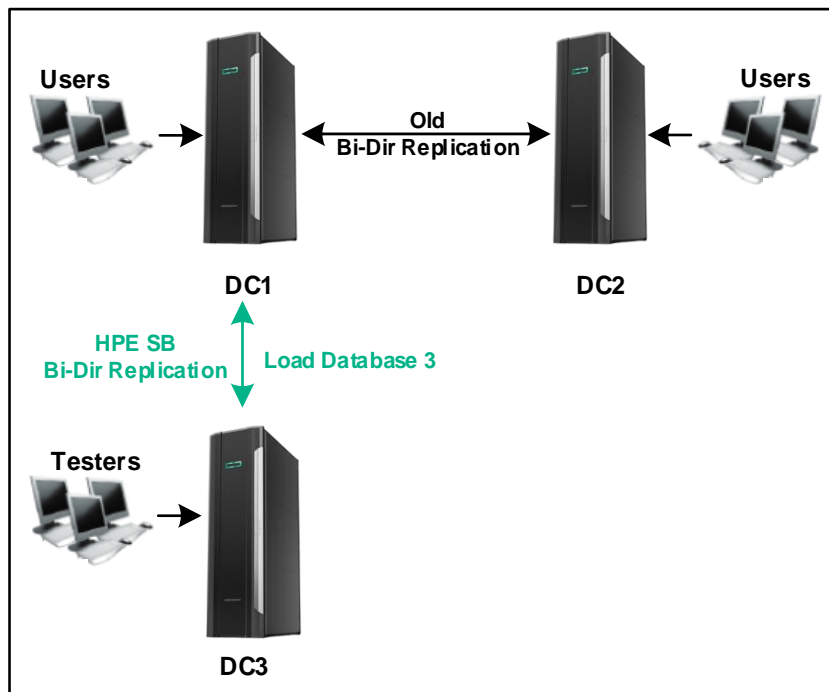

Figure 7 – Add the DC3 Node

Step 2: Migrate Users from DC2 to DC3, Isolating DC2 for the Shutdown/Move

When the test of the DC3 system was successfully completed, the migration of users from the DC2 system to the DC3 system began (Figure 8).

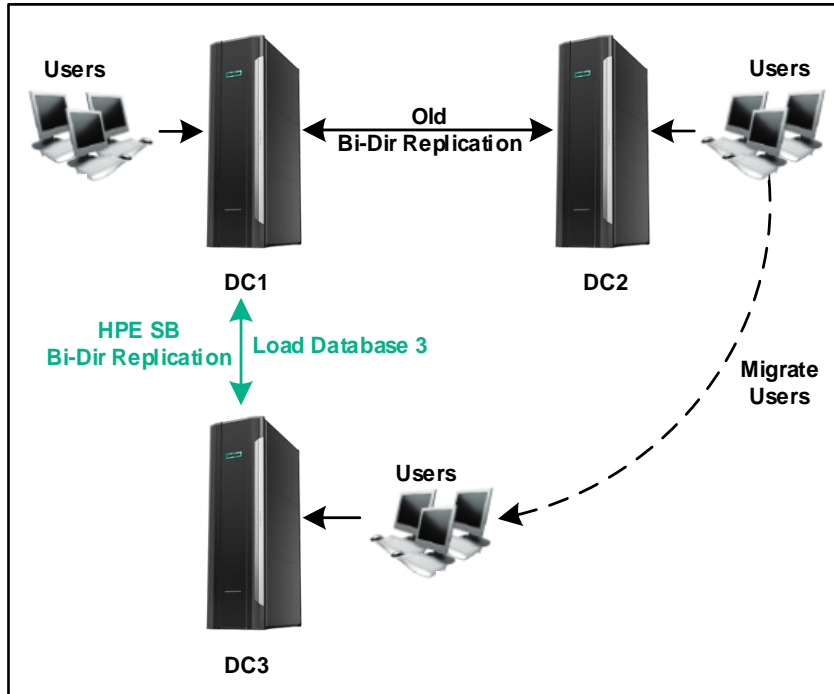

Figure 8 – Migrate Users from DC2 to DC3

Once the migration was completed, the DC2 system no longer had any users attached to it. At this point, the old data replication product that had kept the DC2 database synchronized with the DC1 database was decommissioned, and bi-directional replication between DC3 and DC2 was established using HPE Shadowbase (Figure 9). During this step, the Shadowbase configuration was verified before moving the DC2 system.

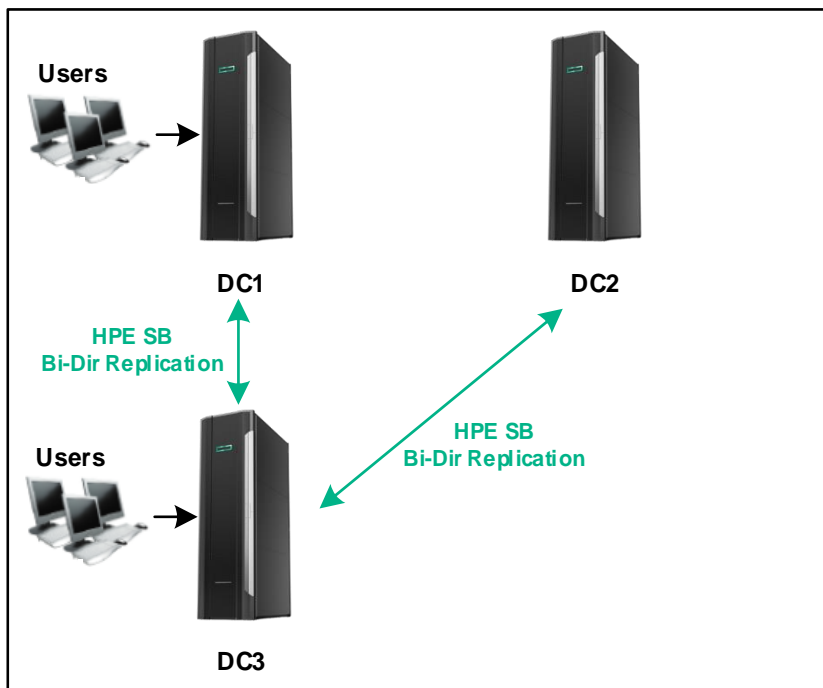

Figure 9 – Migrate Users from DC2 to DC3

Step 3: Shutdown and Move the DC2 System to Datacenter 4 (Rename it to DC4)

Replication between the DC3 and DC2 systems continued until the DC2 system move was ready, and then was paused with a timestamp in order to create a replication restart point. The DC2 system was then shut down and moved to Datacenter 4 (Figure 10).

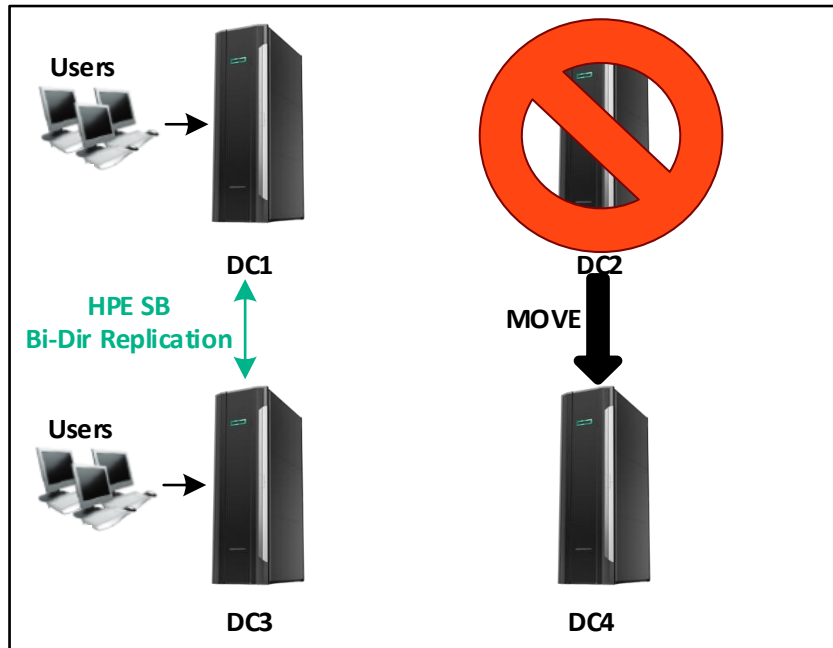

Figure 10 – Shutdown, Move, and Rename DC2 to DC4

The previously validated HPE Shadowbase data replication configuration was then deployed between the DC3 system and the DC4 (previously DC2) system (Figure 11).

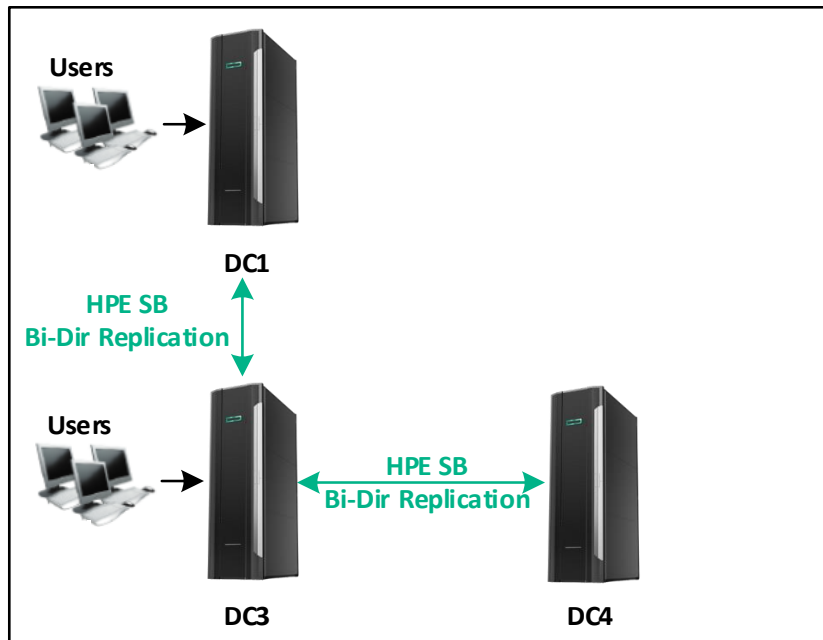

Figure 11 – Move DC2 to DC4

The DC3 queue of database changes that had built during the move was then flushed to the DC4 system by the HPE Shadowbase replication engine from its timestamp replication restart point, thereby making the DC4 database current. The two systems were continuously kept synchronized via the HPE Shadowbase data replication engine.

Step 4: Migrate Users from DC1 to DC4 to Isolate the DC1 System

Next, the users served by the DC1 system were incrementally moved to the DC4 system (Figure 12).

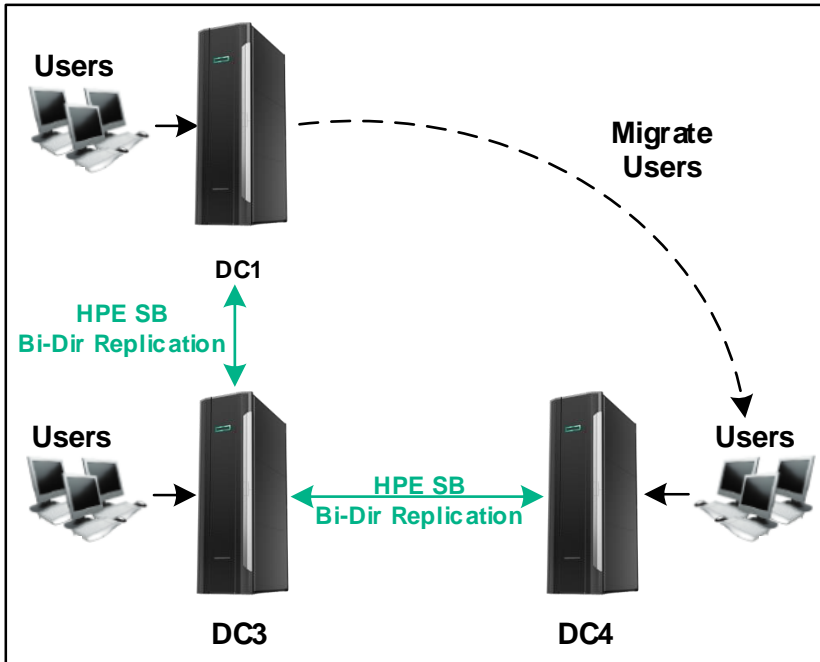

Figure 12 – Migrate Users from DC1 to DC4

Step 5: Retire the DC1 System to Create the Final DC3/DC4 Active/Active Solution

After all the users were migrated to the DC4 system, no users were left on the DC1 system. So, the HPE Shadowbase data replication engine connecting the DC1 and DC3 systems was decommissioned, and the DC1 system was retired, resulting in the final configuration (Figure 13).

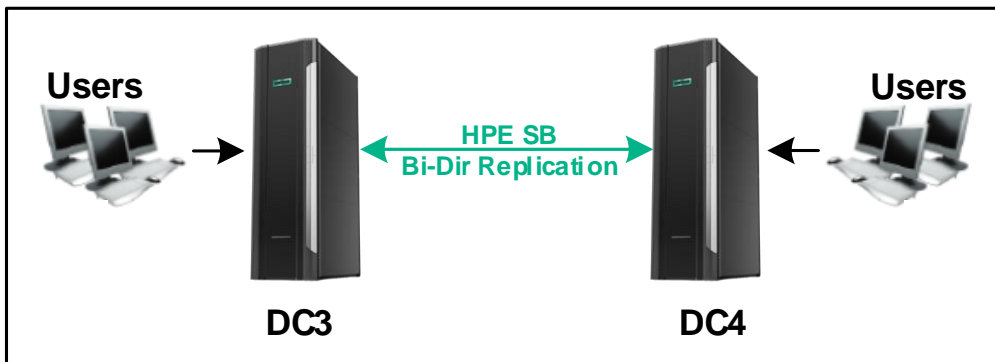

Figure 13 – Retire the DC1 System

Summary

This migration presented a number of challenging parallel requirements:

- Complete within a few weeks
- No application downtime
- Full business continuity protection maintenance at all times (meaning at least two systems continuously available in the event that one system failed)
- Physical replacement (upgrade) of one hardware system
- Replacement of the existing data replication software product with a new product (HPE Shadowbase)
- Relocation of all systems and networks to new datacenters in other cities
- Minimal risk, only proceed to the next step once the current step is tested and proven
- Easily accomplish failback of each step if necessary

These requirements were undeniably challenging, but the fact that they all were met is testament to the power of the HPE Shadowbase ZDM approach, which allowed for the migration of systems with no application downtime. The company used HPE Shadowbase ZDM to change its data replication software product, to move its active/active system to two new cities, and to perform a system upgrade in the process. During all of these activities, the company suffered no application downtime.

International Partner Information

Global

Hewlett Packard Enterprise

6280 America Center Drive
San Jose, CA 95002
USA

Tel: +1.800.607.3567

www.hpe.com

Japan

High Availability Systems Co. Ltd

MS Shibaura Bldg.
4-13-23 Shibaura
Minato-ku, Tokyo 108-0023
Japan

Tel: +81 3 5730 8870

Fax: +81 3 5730 8629

www.ha-sys.co.jp

HPE Shadowbase Contact Information

17 General Warren Blvd.
Malvern, PA 19355-1245
USA

Tel: +1.610.647.6250

Fax: +1.610.647.7958

www.shadowbasesoftware.com

Email Sales: shadowbase@gravic.com

Email Support: sbsupport@gravic.com



Copyright and Trademark Information

This document is Copyright © 2017, 2020 by Gravic, Inc. Gravic, Shadowbase and Total Replication Solutions are registered trademarks of Gravic, Inc. All other brand and product names are the trademarks or registered trademarks of their respective owners. Specifications subject to change without notice.